



Mini DVI Switcher

EXT-MINIDVI-241N

User Manual



www.gefen.com

ASKING FOR ASSISTANCE

Technical Support:

Telephone (818) 772-9100
(800) 545-6900

Fax (818) 772-9120

Technical Support Hours:

8:00 AM to 5:00 PM Monday through Friday.

Write To:

Gefen Inc.
C/O Customer Service
20600 Nordhoff St
Chatsworth, CA 91311

www.gefen.com
support@gefen.com

Notice

Gefen Inc. reserves the right to make changes in the hardware, packaging and any accompanying documentation without prior written notice.

Mini DVI Switcher is a trademark of Gefen Inc.

TABLE OF CONTENTS

- 1 Introduction
- 2 Features
- 3 Panel Descriptions
- 4 Connecting and Operating the Mini DVI Switcher
- 5 RMT2-IR Installation
- 6 IR Code Configuration
- 7 Specifications
- 8 Warranty

INTRODUCTION

Congratulations on your purchase of the ex•tend•it Mini DVI Switcher. Your complete satisfaction is very important to us.

Gefen's line of DVI switches, extenders, and splitters are designed to make your A/V equipment use more comfortable, more productive and less expensive.

The ex•tend•it Mini DVI Switcher enables effortless DVI video source switching using a single DVI display. A simple, reliable and economical solution, the Mini DVI Switcher links any two DVI sources to one DVI display. It completely eliminates the need to disconnect then reconnect multiple DVI sources, saving time by providing a fundamental tool that brings it all together behind the scenes. When all three devices (the display plus the two sources) are connected to the Mini DVI Switcher and powered on, you simply select which source you want to view on the display using the Switcher, the IR remote that comes with it, or any universal remote you program to work with the Switcher.

The ex•tend•it line offers solutions for noise, space and security concerns, data center control, information distribution, conference room presentation, school and corporate training environments.

Our Commitment

Gefen will always offer the finest quality product at the best possible price. Included in that price is a lifetime of support from a team of outstanding engineers.

How It Works

Simply connect your DVI display to the Switcher's display output. Then connect both DVI sources to the Switcher's inputs using the DVI cables that come with the Switcher. Once the sources, the Switcher and the display are all powered on and connected, you simply select which source you want to view.

FEATURES

Features

- Saves money on hardware—no need to purchase multiple DVI displays
- Saves space—a single DVI display
- Saves time—no need to disconnect and reconnect DVI devices—everything is always connected and accessible
- Maintains high resolution video—beautiful, sharp DVI resolutions up to 1080P are easily achieved. For computer users, the Mini DVI Switcher conforms with DVI 1.0 specifications for resolutions up to 1920 x 1200.
- No loss of quality—the integrity of the signal is preserved throughout the transmissions using high caliber DVI cables that ensure the signal is maintained
- Operational flexibility—you can switch at the source, with the IR remote control or your own universal remote
- Compatible with all DVI-equipped. To determine if your device is DVI-equipped, simply look for the 24-pin connector on the back of the unit. For computer users, the Mini DVI Switcher is compatible with all DVI-equipped computers and supports Apple's line of flat panel displays when used with the DVI to ADC Conversion Box.
- Easy to install and simple to operate

Includes:

- (1) Mini DVI Switcher
- (2) 6' DVI-D cables (M-M)
- (1) 5VDC Power Supply
- (1) RMT2-IR
- (1) User's Manual

PANEL DESCRIPTIONS

Front

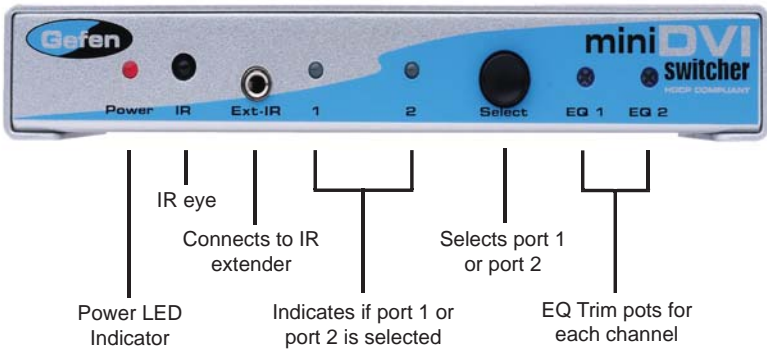

Back

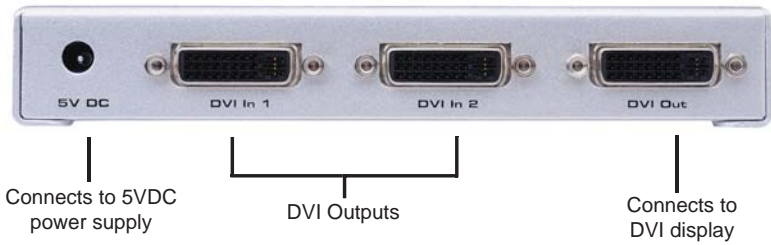

CONNECTING AND OPERATING THE MINI DVI SWITCHER

How to Connect the Mini DVI Switcher to your devices

- 1 Connect the supplied DVI cables from the DVI sources into the DVI Switcher Input.
- 2 Connect the cable from your display (monitor or projector) into the DVI Out of the Mini DVI Switcher.

How to Operate the Mini DVI Switcher

- 1 Use the front panel push button to switch between sources.
- 2 Alternatively, use the RMT2-IR remote control port to remotely toggle between sources.

Operation Notes

The output signal may need to be equalized depending on the length and quality of the DVI cables that are being used. If, after connecting all equipment and powering on the system, there is either no picture or video noise on the output display device, the signal may have to be equalized. To do this, follow the steps below.

1. Locate the equalization Trim Pots on the front panel of the Mini DVI switcher.
2. Insert small flat-headed adjustment tool into the Trim Pot and turn it in either a clock-wise or counter clock-wise direction until the image appears and/or stabilizes. The Trim Pot can only be turned approximately one full revolution. Do not force the Trim Pot beyond the point where it initially stops or it may be rendered useless.
3. Once the desired setting has been achieved, remove the adjustment tool.

RMT2-IR INSTALLATION

1. Remove battery cover from the back of the RMT2-IR remote.
2. Verify that dip switches 1 & 2 are in the down (OFF) position.
3. Hold the battery so that you can see the positive side facing up. The side that is not marked must be facing down.
5. Insert the battery into the open battery slot in the remote control.
7. Test the RMT2-IR remote by pressing ONLY one button at a time. The indicator light on the remote will flash once each time you press a button. **WARNING:** Do not press multiple buttons simultaneously and do NOT press buttons rapidly. These actions will cause the remote to reset and steps 1-7 will have to be repeated.

Note: The RMT2-IR ships with two batteries. One battery is required for operation, the second battery is complimentary.



The optional IR extender allows you to re-locate your Mini DVI Switcher and still have IR control of the Mini DVI Switcher

IR CODE CONFIGURATION

Why would I need to change the remote channel?

In some instances, the Mini DVI Switcher may use IR codes that conflict with other IR remote control devices. The unit may switch inputs when another brand IR remote control is used or the RMT-2IR may cause other brand IR controlled devices to behave unexpectedly.

I am experiencing the issues listed above. What do I do?

In these cases it is recommended to change the IR channel that the RMT-2IR remote control and the Mini DVI Switcher use. The IR channel is configured independently on the RMT-2IR remote control and the Mini DVI Switcher but the channel selection must match on both units for proper operation.

How Do I change the Remote Channel?

There are service DIP switches on the RMT-2IR remote control and also inside the Mini DVI Switcher. Use the diagrams below to locate and change the IR channel to one that is not the default. Remember that the channel must match on both the unit and remote control for successful operation.

RMT-2IR Remote Control

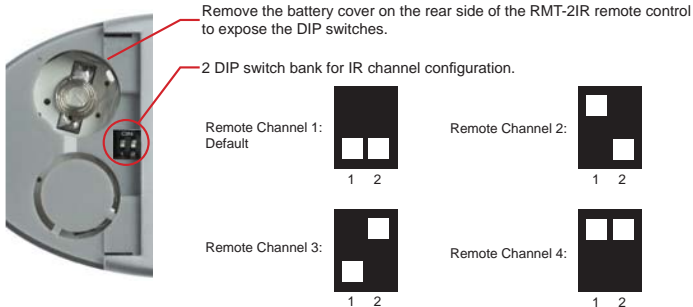

Mini DVI Switcher

The IR channel DIP switches for the Mini DVI Switcher are located on an 4 bank DIP switch on the underside of the unit and covered with a piece of silver colored metallic tape. Locate DIP switches 3 and 4. Once adjustments are complete replace all screws and.

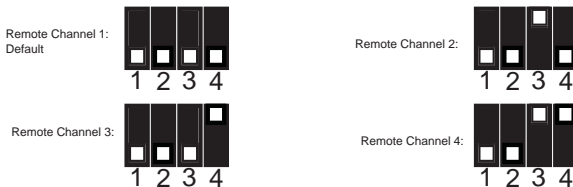

SPECIFICATIONS

Video Amplifier Bandwidth	1.65 GHz
Input Video Signal	1.2 volts p-p
Input DDC Signal	5 volts p-p (TTL)
Single Link Range	1920 x 1200
DVI Input/Output Connector Type	DVI-D
Power Consumption	15 Watts (max.)
Power Supply	5VDC
Dimensions	4"D x 1"W x 4"H
Shipping Weight	2 Lbs